

Information Sheet

LiquiPro™ Bleed / 4-Function Valve For 300/400 Series Cartridge Valve Type Liquid Ends

Continuous Bleed

The LMI Bleed / 4-Function Valve is designed to permit an adjustable, continuous bleed or degassing of entrapped vapors.

This valve is ideal for pumping small volumes of solutions having low vapor pressures.

Anti-Syphon

A positive diaphragm-type anti-syphon function makes it possible to meter liquids "downhill".

Back Pressure

Supplies approximately 20 psi (1.4 Bar) back pressure to prevent over-pumping when little or no system back pressure is present.

Line Depressurization

By opening bleed port, the discharge line will depressurize, without having to loosen tubing or fittings.

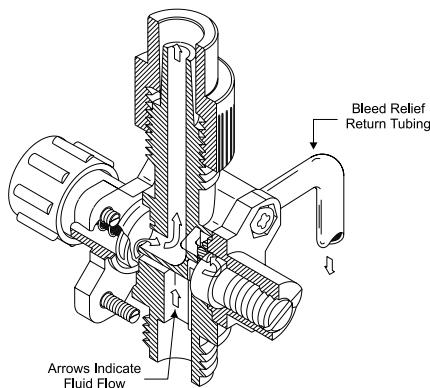
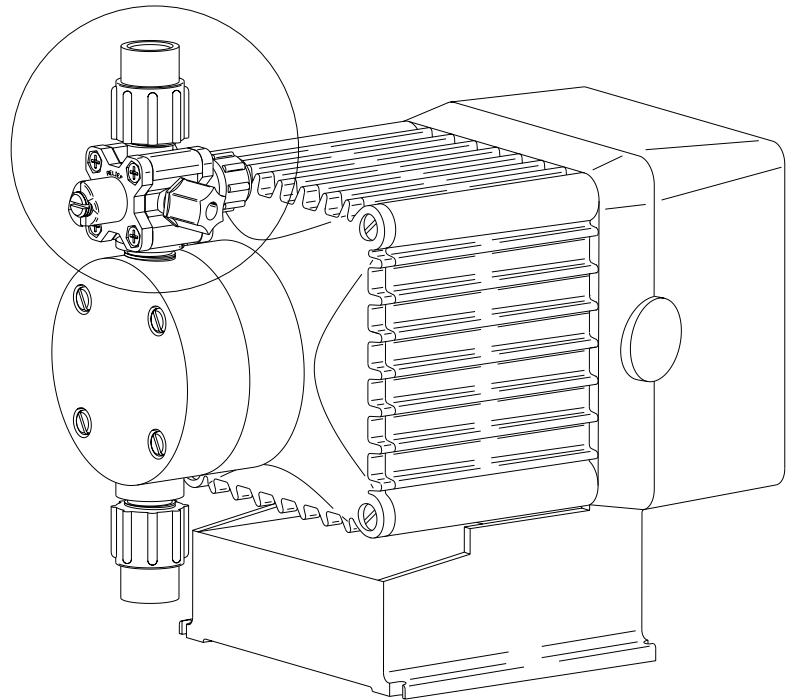

Part No.	Tubing Size	Materials of Construction		
		Body	O-Ring	Diaphragm
36389	1/4" O.D. Tubing	PVDF	Polyprel®	PTFE
36390	3/8" O.D. Tubing	PVDF	Polyprel®	PTFE
37075	1/2" O.D. Tubing	PVDF	Polyprel®	PTFE
36393	1/4" NPT Pipe	PVDF	Polyprel®	PTFE
37995	1/4" O.D. Tubing	PVC	Polyprel®	PTFE
38004	3/8" O.D. Tubing	PVC	Polyprel®	PTFE
38015	1/2" O.D. Tubing	PVC	Polyprel®	PTFE
37984	1/4" NPT Pipe	PVC	Polyprel®	PTFE

Part numbers are for 300/400 Series LiquiPro™ cartridge valve type Liquid Ends only. See Publication #1746 for ball and seal ring type Bleed/4-Function valves.



8 Post Office Square
Acton, MA 01720 USA
TEL: (978) 263-9800
FAX: (978) 264-9172
<http://www.lmipumps.com>



Instruction Sheet

LiquiPro™ Bleed / 4-Function Valve For 300/400 Series Cartridge Valve Type Liquid Ends

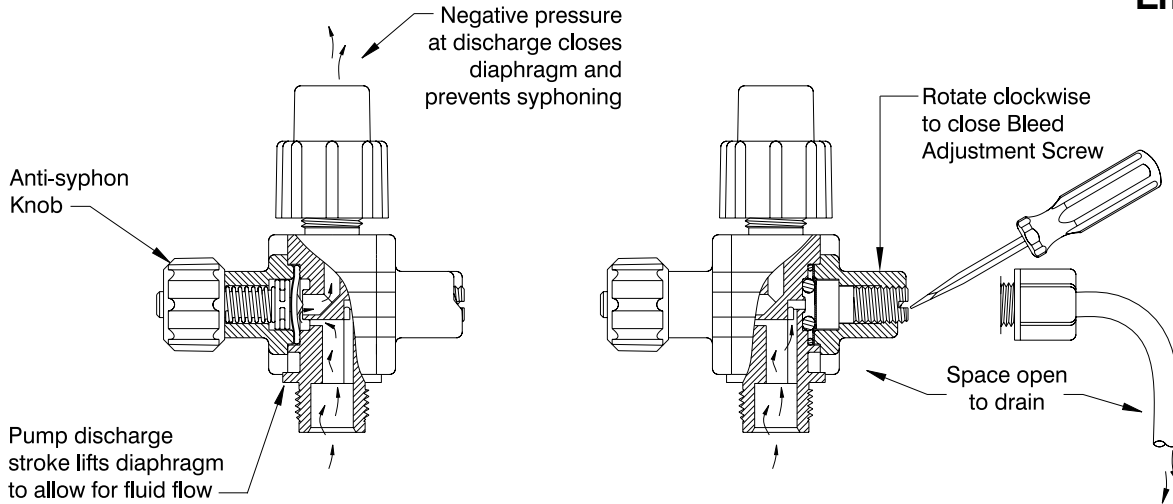

METHOD OF OPERATION

A. PRIMING

1. Connect bleed return tubing to bleed (relief) port.
2. Route tubing to solution tank. Be sure the end of tubing is above the maximum solution level. **Do not submerge tubing in solution.**
3. Set pump at 80% speed and 100% stroke. Start pump. With screwdriver rotate bleed adjustment screw counterclockwise \curvearrowright two (2) full turns. When solution begins to flow through translucent bleed return tubing, the pump is primed.
4. Stop pump.

NOTE:

- (a) Pump is normally self-priming if suction lift is no more than 5 ft (1.5 m), valves in the pump are wet with water (pump is shipped from factory with water in pump head) and the above steps (A1 through A3) are followed.
- (b) If the pump does not self prime, remove Bleed/ 4 Function Valve and Discharge Cartridge Valve, and pour water or solution slowly into discharge port until it is filled. Replace Cartridge Valve, and follow steps (A1 through A3) thereafter.

B. BLEED ADJUSTMENT

1. Start pump and let pump inject solution into the discharge line.
2. Close the bleed adjustment screw by rotating it clock-

wise \curvearrowright with a screwdriver.

3. Now adjust the pump stroke length and/or speed (frequency) to a range approximately 25% higher than you would normally want for the process.
4. Slowly rotate bleed adjustment screw counter-clockwise \curvearrowleft until just a small amount of solution begins to trickle down inside the bleed return tubing. A small amount of solution pumped back to the tank with each stroke of the pump will allow gas and air to escape without air or gas locking in the pump head.

C. DEPRESSURIZING DISCHARGE LINE

1. It is possible to depressurize discharge line and pump head without removal of tubing or loosening of fittings.

Be sure injection check valve is properly installed and is operating. If a gate valve or globe has been installed downstream of injection check valve, it should be closed. Be certain bleed return tubing is connected and run to solution supply tank.

2. With a screwdriver, rotate bleed adjustment screw counter-clockwise \curvearrowleft two (2) full turns. A small amount of solution in discharge line should drain back to the supply tank.
3. The discharge line is now depressurized.
4. If injection check valve is of higher elevation than pump head, disconnecting tubing at injection check valve end will allow air to enter and cause solution to drain back to tank.



**8 Post Office Square
Acton, MA 01720 USA
TEL: (978) 263-9800
FAX: (978) 264-9172
<http://www.lmipumps.com>**