



Griffco Valve Inc.

6010 North Bailey Ave., Ste 1B

Amherst, NY 14226

Phone: 1 716 835-0891

Fax: 1 716 835-0893

ARV PRIMING VALVE



Features:

- Manual Pump Priming
- Manual Pump Head Degassing
- Optional Automatic Degassing
- Multiple Vent Line Connections
- Multiple Materials of Construction
- Integral Mounting Design
- Optional 350 PSI Rated Valve

Operation:

The priming / degassing valve is used in a chemical feed system to remove the discharge pressure from the pump head to facilitate priming on start-up or degassing in the event of airlock. The priming valve is mounted on the upstream side of the backpressure valve between the pump discharge and the valve. When the priming / degassing valve is open there is no pressure on the pump head. The discharge from the priming valve should be returned to the storage tank.

For automatic degassing an electric solenoid valve of compatible material is installed on the back pressure valve. When the pump starts a timer is triggered and the solenoid valve is opened for a predetermined time.

Griffco diaphragm backpressure valves are designed to enhance the performance of chemical feed systems. The addition of a priming valve to the backpressure valve enables the manual priming of the chemical feed pump. Available in PVC, PP, PVDF and 316 SS. Others available on request.

TYPICAL INSTALLATION

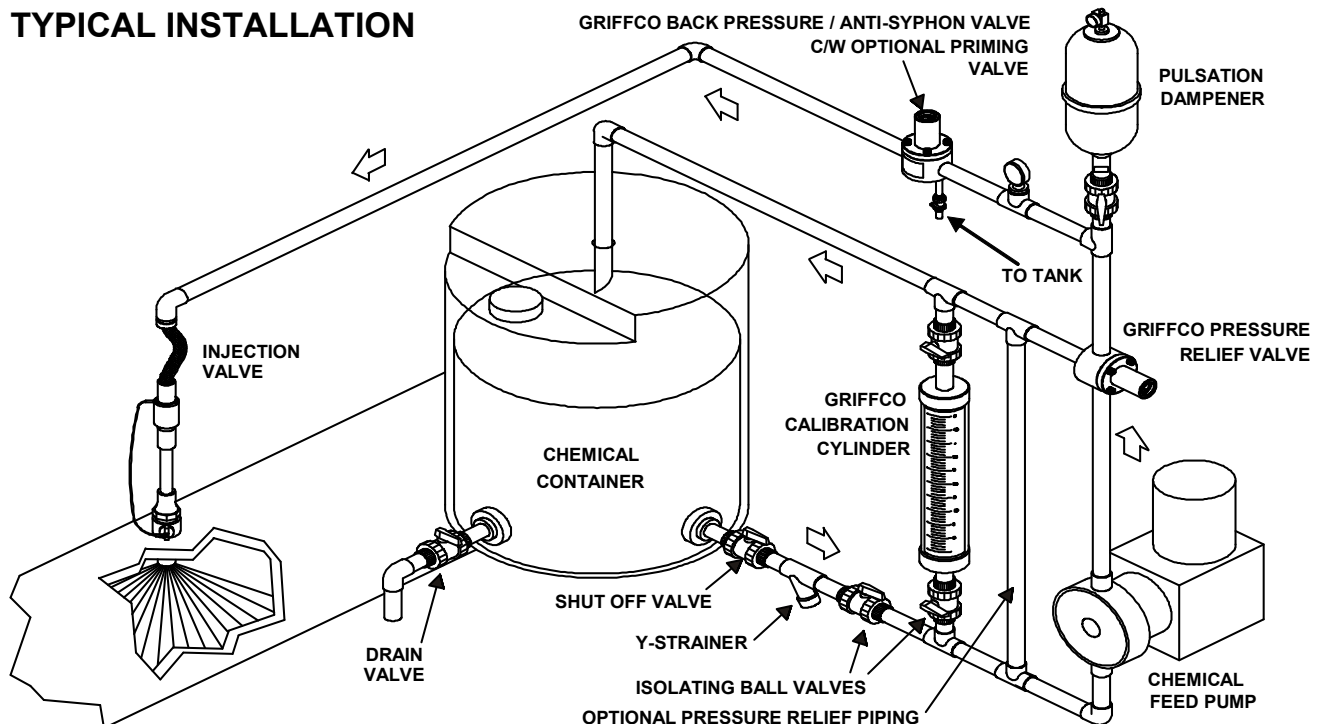

CALL 1 - 800 - GRIFFCO

Bulletin # ARV001 - 2006