

Liquid End Sheet

LE-150S/LE-150SU

When pumping solutions, make certain that all tubing is securely attached to the fittings. It is recommended that tubing or pipe lines be shielded to prevent possible injury in case of rupture or accidental damage. Always wear protective clothing and face shield when working on or near your metering pump.

Note: See parts list for materials of construction

A. INSTALLING INJECTION CHECK VALVE

1. The purpose of the injection check valve is to prevent backflow from the treated line.
2. A 1/2" NPT female fitting with sufficient depth will accept the injection check valve.
3. To insure correct seating of the ball inside the injection check valve, the injection check valve should be installed upwards (vertically) into bottom of the pipe.

B. CONNECTING DISCHARGE TUBING

NOTE: Cut tubing to length needed for discharge line.

1. Route tubing from the injection check valve to the metering pump, making sure it does not touch hot or sharp surfaces, or is bent so sharply that it kinks.
2. Slide the small end of the coupling nut onto tubing.
3. Slide the long, straight end of the ferrule onto tubing such that tubing exits at the cone shaped end of the ferrule.
4. Insert tubing into the valve housing so that tubing butts up against valve housing and will not go any further.
5. Slide ferrule down so that the cone shaped end fits snugly into valve housing.
4. Slide the coupling nut to the threads and engage. While pushing the tubing into valve housing, tighten the coupling nut by hand until tubing is held securely in place.

Excessive force will crack or distort fittings.

DO NOT USE PIPE WRENCH.

C. CONNECTING SUCTION TUBING

1. Cut suction tubing to a length so that the foot valve hangs just above the bottom of the solution container. Maximum recommended vertical suction lift is 5ft (1.5 m).
2. Follow same procedure in connecting suction tubing to suction valve and foot valve (see **B. Connecting Discharge Tubing**).

D. PRIMING

1. Connect pressure relief tubing to pressure relief port on the four function valve.
2. Route tubing to solution reservoir and anchor with a plastic tie. Do not submerge tubing in solution.
3. Start pump. Set at 80% speed and 100% stroke.
4. Pull on Pressure Relief knob (red or black knob), holding knob out until solution is visible through translucent return tubing.
5. The pump is now primed.

NOTE:

- (a) Pump is normally self-priming if suction lift is not more than 5 ft (1.5 m), valves in the pump are wet with water (pump is shipped from factory with water in pump head) and the above steps (**D. Priming**) are followed.
- (b) If the pump does not self prime, remove discharge valve housing and ball and pour water or solution slowly into discharge port until head is filled. Follow step **D. Priming** thereafter.

E. DEPRESSURIZING DISCHARGE LINE

1. It is possible to depressurize the discharge line and pump head without removal of tubing or loosening of fittings.

Be sure injection check valve is properly installed and is operating. If a gate valve or globe has been installed downstream of injection check valve, it should be closed. Be certain relief tubing from the four function valve is connected and run to solution reservoir.

2. Pull on both anti-syphon and relief knobs.
3. The discharge line is now depressurized.
4. If injection check valve is of higher elevation than pump head, disconnecting tubing at injection check valve end will allow air to enter and cause solution to drain back to tank.



8 Post Office Square
Acton, MA 01720 USA
TEL: (978) 263-9800
FAX: (978) 264-9172
<http://www.lmipumps.com>



NOTE:

Threaded connections into pump head are 3/4"-16 straight threads. **DO NOT USE TEFLON TAPE.** These joints are sealed by seal ring valve seats.

NOTE:

Maximum pump pressure rating is reduced by 25 psi (1.7 bar) with back pressure spring installed. **Do not remove back pressure spring if pressure at injection point is less than 20 psi (1.4 bar).**

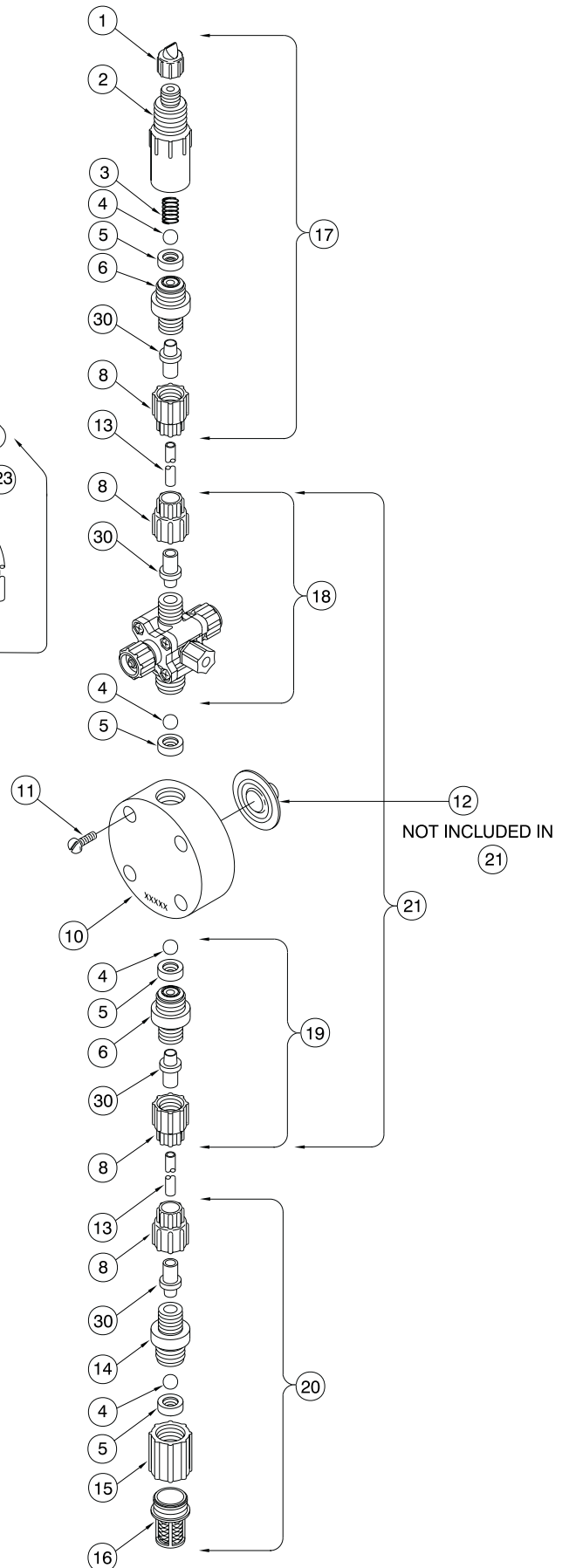
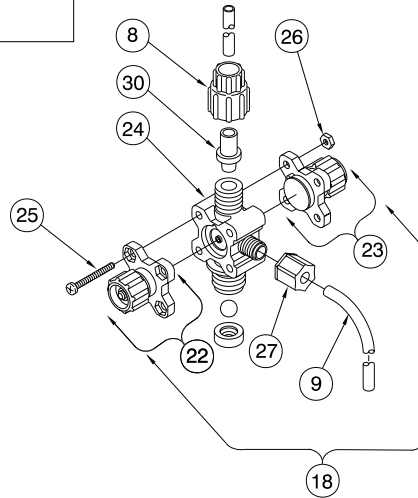

KEY NO.	PART NO.	DESCRIPTION	QUANTITY	
			LE-150S	LE-150SU
1	27352	Flapper Valve, Flexoprene	1	1
2	10394	Injector fitting, PVDF	1	1
3	10339*	Spring, PVDF	1	1
4	10338*	Ball, Ceramic .375"	4	4
5	29443*	Seal Ring, Polyprel	4	4
6	28664	Valve Seat, GFR Polypropylene	2	2
8	10299	Coupling Nut	4	4
9	25636-10	Tubing, .250" O.D. Polyethylene	1	1
10	29599	Head, 0.5 Acrylic	1	1
11	10340	Screw, 10-24 x 3/4" SS	4	4
12	30916*	Liquifram, 0.5 SI Teflon	1	1
13	25636-16	Tubing, .250" O.D. Polyethylene	1	
	28636-16	Tubing, .250" O.D. Polyethylene (blk)		1
14	28665	Valve Housing, GFR Polypropylene	1	1
15	10978	Foot Valve Seat	1	1
16	10123	Strainer, Polypropylene	1	1
17	28001	Inj. Check/Valve Assembly	1	1
18	28010	Anti-Syphon/Press. Relief Valve Asm	1	
	31693	Anti-Syphon/Press. Relief Valve Asm		1
19	28004	Suction Valve Asm	1	1
20	28002	Foot Valve Asm	1	1
21	29673	Head Asm, LE-150S	1	
	31691	Head Asm, LE-150SU		1
22	25837	Relief Cap Assembly	1	1
23	25838	Anti-Syphon Cap Assembly	1	1
24	28703	Valve Body, GFR Polypropylene	1	1
25	25627	Screw, 6-32 x 1 1/4" SS	4	4
26	25628	Nut, Hex 6-32 SS	4	4
27	25631	Coupling Nut	1	1
30	28663	Ferrule	4	4
Not Shown	32293	Suction Tubing Straightener	1	1

*Parts included in Spare Parts Kit Sp-U8