

# LE-151SP

## LIQUID HANDLING ASSEMBLY

### CAUTION

When pumping solutions make certain that all tubing is securely attached to the fittings. It is recommended that tubing or pipe lines be shielded to prevent possible injury in case of rupture or accidental damage. Always wear protective clothing and face shield when working on or near your metering pump.

*Note: See parts list for materials of construction*

#### A. INSTALLING INJECTION CHECK VALVE

1. The purpose of the injection check valve is to prevent backflow from the treated line.
2. A 1/4" NPT female fitting with sufficient depth will accept the injection check valve.
3. To insure correct seating of the ball inside the injection check valve, the injection check valve should be installed upwards (vertically) into bottom of the pipe.

#### B. CONNECTING DISCHARGE PIPE

##### NOTE:

*Corrosion resistant 1/4" Schedule 80 or Schedule 120 should be used. DO NOT USE SMALLER PIPE SIZES.*

1. Discharge valve has a 1/4" NPT male outlet. A short 1/4" NPT union should be connected to both discharge and suction valves so that the metering pump may be removed without disturbing piping.
2. It is recommended that Teflon tape be used on tapered pipe threads so that there is a leakproof seal without overtightening of fittings.

**EXCESSIVE FORCE WILL CRACK OR DISTORT FITTINGS.  
DO NOT OVERTIGHTEN.**

#### C. CONNECTING SUCTION PIPE

1. Using the same size and material pipe as used on the discharge line, cut the suction pipe to length so that the foot valve is positioned just above the bottom of the solution container. Maximum recommended vertical suction lift is 5 ft. (1.5m).
2. It is recommended that Teflon tape be used on tapered pipe threads so that there is a leakproof seal without overtightening of fittings. Suction side leaks are invisible, but if present will cause pump to suck in air during each pump stroke.

#### D. PRIMING

1. Connect pressure relief tubing to pressure relief port on the four function valve.
2. Route tubing to solution reservoir and anchor with a plastic tie. Do not submerge tubing in solution.
3. Start pump. Set at 80% speed and 100% stroke.
4. Pull on Pressure Relief knob (red or black knob), holding knob out until solution is visible through translucent return tubing.
5. The pump is now primed.

##### NOTE:

*(a) Pump is normally self-priming if suction lift is not more than 5 ft. (1.5m), valves in the pump are wet with water (pump is shipped from factory with water in pump head) and the above steps (D. Priming) are followed.*

*(b) If the pump does not self prime, remove discharge valve housing and ball and pour water or solution slowly into discharge port until head is filled. Follow step D. Priming thereafter.*

#### E. DEPRESSURIZING DISCHARGE LINE

1. It is possible to depressurize the discharge line and pump head without removal of tubing or loosening of fittings.

*Be sure injection check valve is properly installed and is operating. If a gate valve or globe has been installed downstream of injection check valve, it should be closed. Be certain relief tubing from the four function valve is connected and run to solution reservoir.*

2. Pull on both anti-syphon and relief knobs.
3. The discharge line is now depressurized.
4. If the injection check valve is of higher elevation than the pump head, disconnecting tubing at the injection check valve end will allow air to enter and cause the solution to drain back to the tank.



**LMI**  
LIQUID METRONICS DIVISION  
**MILTON ROY**

8 Post Office Square  
Acton, MA 01720 U.S.A.  
TEL (508) 263-9800  
FAX (508) 264-9172

**Note:** Threaded connections into pump head are 3/4" - 16 straight threads. **DO NOT USE TEFLON TAPE.** These joints are sealed by seal ring valve seats (item 5 on exploded view).

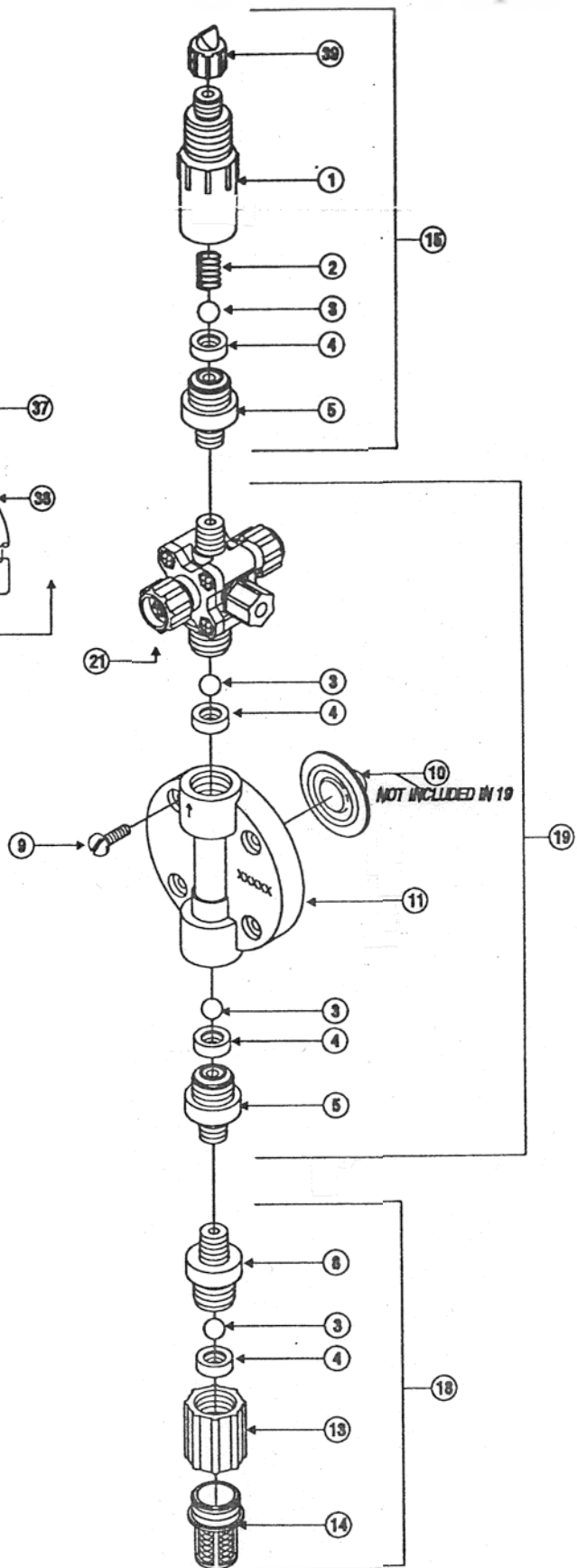
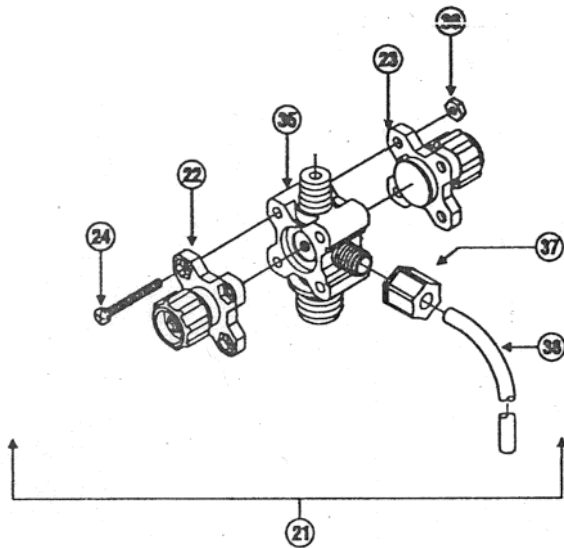

KEY NO.	PART NO.	DESCRIPTION	QTY.
1	10394	Injector Fitting	1
2	10339*	Spring	1
3	10338*	Ball, Ceramic	4
4	29443*	Seal Ring, Polyprel™	4
5	10972-1	Valve Seat, PP	2
8	10793-1	Valve Housing, PP	1
9	10340	Screw	4
10	30916*	Liquifram™	1
11	29608	Head, PP	1
13	10978	Foot Valve Seat	1
14	10123	Strainer	1
15	31040	Injection Valve Assembly	1
18	31039	Foot Valve Assembly	1
19	33112	Head Asm., LE-151SP	1
21	26615	Anti-Syphon/Pressure Release Valve	1
22	25837	Pressure Relief Cap Assembly	1
23	25838	Anti-Syphon Cap Assembly	1
24	25627	Screws	4
35	25870-1	Valve Body	1
36	25628	Nut	4
37	25631	Ferrule Nut	1
38	25636-10	Tubing, .250" O.D. Polyethylene	1
39	27352	Flapper Valve	1

\*Parts included in Spare Parts Lit No. SP-U1