

LE-52T

LIQUID HANDLING ASSEMBLY

CAUTION

When pumping solutions make certain that all tubing is securely attached to the fittings. It is recommended that tubing or pipe lines be shielded to prevent possible injury in case of rupture or accidental damage. Always wear protective clothing and face shield when working on or near your metering pump.

Note: See parts list for materials of construction

A. INSTALLING INJECTION CHECK VALVE

1. The purpose of the injection check valve is to prevent backflow from the treated line.
2. A 1/2" NPT female fitting with sufficient depth will accept the injection check valve.
3. To insure correct seating of the ball inside the injection check valve, the injection check valve should be installed upwards (vertically) into bottom of the pipe.

B. CONNECTING DISCHARGE TUBING

NOTE:

Cut tubing to length needed for discharge line.

1. Route tubing from the injection check valve to the metering pump, making sure it does not touch hot or sharp surfaces, or is bent so sharply that it kinks.
2. Slide the small end of the coupling nut onto tubing.
3. Slide the long, straight end of the ferrule onto tubing such that tubing exits at the cone shaped end of the ferrule.
4. Insert tubing into the valve housing so that tubing butts up against valve housing and will not go any further.
5. Slide ferrule down so that the cone shaped end fits snugly into valve housing.
6. Slide the coupling nut to the threads and engage. While pushing the tubing into valve housing, tighten the coupling nut by hand until tubing is held securely in place.

C. CONNECTING SUCTION TUBING

1. Cut suction tubing to a length so that the foot valve hangs just above the bottom of the solution container. Maximum recommended vertical suction lift is 5 ft. (1.5m).
2. Follow same procedure in connecting suction tubing to suction valve and foot valve (see B. Connecting Discharge Tubing).

D. PRIMING

1. Temporarily remove tubing from the injection check valve and hold the end of tubing so it is above the level of the pump.
2. Start pump. Set at 80% speed and 100% stroke.
3. As soon as solution is visible through translucent discharge tubing, just past the discharge valve, stop the pump.
4. The pump is now primed.
5. Reconnect tubing to the injection check valve.

NOTE:

(a) Pump is normally self-priming if suction lift is not more than 5 ft. (1.5m), valves in the pump are wet with water (pump is shipped from factory with water in pump head) and the above steps (D. Priming) are followed.

(b) If the pump does not self prime, remove discharge valve housing and ball and pour water or solution slowly into discharge port until head is filled. Follow step D. Priming thereafter.

**EXCESSIVE FORCE WILL CRACK OR DISTORT FITTINGS.
DO NOT USE PIPE WRENCH.**



LMI
LIQUID METRONICS DIVISION
MILTON ROY

ISO9001 Certified • a unit of Sundstrand Corporation

8 Post Office Square
Acton, MA 01720 U.S.A.
TEL (508) 263-9800
FAX (508) 264-9172

Note: Threaded connections into pump head are 3/4" - 16 straight threads. **DO NOT USE TEFLON TAPE.** These joints are sealed by seal ring valve seats (Item 5 on exploded view).

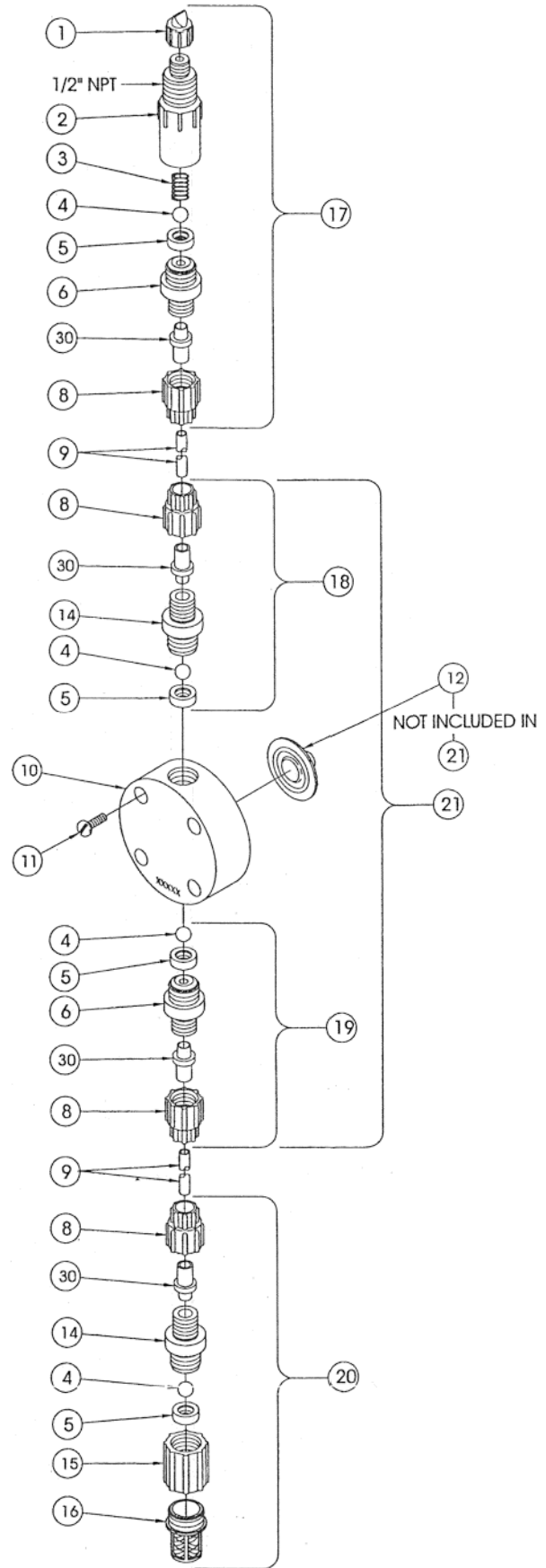

KEY NO.	PART NO.	DESCRIPTION	QUANTITY
			LE-52T
1	27352	Flapper Valve, Flexoprene	1
2	10294	Injector Fitting, PVC	1
3	10339*	Spring, PVDF	1
4	10338*	Ball, Ceramic .375	4
5	10407*	Seal Ring, Teflon	4
6	30383	Valve Seat, PVC	2
8	10299	Coupling Nut	4
9	25636-16	Tubing, .250" O.D. Polyethylene	1
10	35396	Head, 0.5 SI PVC	1
11	10340	Screw, 10-24 x 3/4" SS	4
12	30916*	Liquifram, 0.5 SI Fluorofilm	1
14	30375	Valve Housing, PVC	2
15	10978	Foot Valve Seat	1
16	10123	Strainer, Polypropylene	1
17	35427	Inj. Check Valve Assembly	1
18	35425	Discharge Valve Assembly	1
19	35426	Suction Valve Asm	1
20	35428	Foot Valve Asm	1
21	35422	Head Asm, LE-52T	1
30	28663	Ferrule	4
---	32293	Suction Tubing Straightener (not shown)	1

*Parts included in Spare Parts Kit SP- U9