

TROUBLESHOOTING GUIDE

Most MixMate systems are sized correctly and work well right “out of the box”. In a few cases, however, actual field conditions may call for some changes after the unit has been installed and started up. Sometimes the system will have been bid to a general specification, or the polymer changed, or it’s just that a fine tuning of the MixMate’s performance is desired. The most common indication of a problem is plugging in the Injection Module or Static Mixer. The most common cause will be too strong a polymer concentration, contaminated polymer, or simply that the flow velocities through the system are too low. If increasing the water flow rate or decreasing the polymer pump output doesn’t fix the problem, then a physical modification of the MixMate may be required. Changes can be made in most nozzle orifice sizes, flowmeter ranges, and mixer configurations. If your problem can’t be solved by the suggestions in the table below, please give us a call.

PROBLEM	CAUSE	SOLUTION
Fisheyes in Product Water	Polymer not in solution	<ul style="list-style-type: none"> • Increase water flow rate • Decrease polymer feed • Increase system flow velocity (See Notes 1 and 2)
Polymer not Fully Activated	Low flow velocities	<ul style="list-style-type: none"> • Increase water flow rate (See Notes 1 and 2)
	Shear in mixer	<ul style="list-style-type: none"> • Remove mixer element (See Note 3)
Flowmeter Hard to Read	Dirt/solids build-up	<ul style="list-style-type: none"> • Remove meter body and clean • Use cartridge filter or Y-strainer • Use softened water supply
	Polymer back-up	<ul style="list-style-type: none"> • Increase water flow rate • Put check valve in after mixer
Eductor Nozzle Plugged	Dirt/solids build-up	<ul style="list-style-type: none"> • Remove nozzle assembly and clean • Use cartridge filter or Y-strainer • Use softened water supply • Increase nozzle flow velocity (See Note 2)
Injector Plugged	Solids build-up at flapper	<ul style="list-style-type: none"> • Remove Injector and clean • Check that white dots are lined up on Injection Module • Decrease polymer feed • Contaminated polymer – check source • Increase system flow velocity (See Notes 1 and 2)
Mixer Plugged	Solids build-up in mixer	<ul style="list-style-type: none"> • Remove mixer elements and clean • Increase water flow rate • Decrease polymer feed • Contaminated polymer – check source • Increase mixer flow velocity (See Notes 1 and 2)
Insufficient Delivery Force	Too much pressure drop	<ul style="list-style-type: none"> • Remove mixer element (See Note 3) • Too much discharge plumbing back pressure – increase line size and/or move system nearer to application point • Review nozzle orifice size (See Note 2)

TROUBLESHOOTING GUIDE

Note 1 - FLOWMETER: For flowmeters with maximum flows of 0.25, 1.0, 2.0 and 5.0 GPM, the Meter Body and Float can be easily exchanged one for another. These flowmeters come with union fittings at their top and bottom, so that loosening those fittings will allow you to remove the complete meter body assembly. This type of change will be called for most often for lower flow Mixmates with 1/4", 3/8" or 3/4 " mixers. Part numbers for the Meter Body and Float assemblies can be found in the table below.

Flowmeter	Meter Body and Float Part Number
0.025 to 0.25 GPM	2002
0.1 to 1.0 GPM	2003
0.2 to 2.0 GPM	2004
0.5 to 5.0 GPM	2005

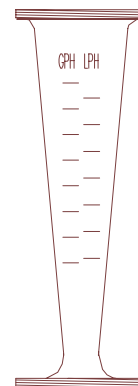

Note 2 - NOZZLE: With a fixed nozzle orifice, an increase in the water flow rate will increase the flow velocity through the system. Depending upon the application, another way to increase the flow velocity is to decrease the nozzle size. This could be called for if the unit is plugging too often or it is felt that the polymer is not being fully activated. Part numbers for the most commonly used Educator Nozzle Assemblies are given in the table below.

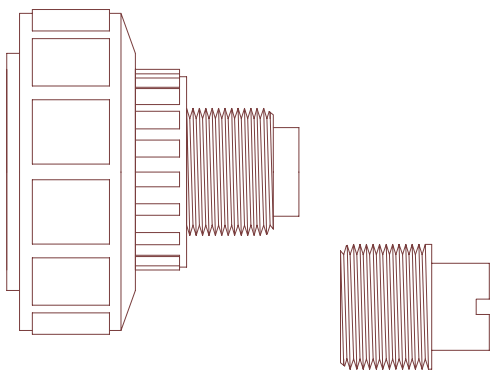

1/4" to 1"

2"

Mixer Size	Educator Nozzle Assembly Part Number				
	1/32"	1/16"	1/8"	1/4"	1/2"
M02	2006	2007	2008		
M03		2007	2008	2009	
M07		2007	2008	2009	
M10			2010	2011	
M20					2012

Note 3 - MIXER: If your mixer is contributing to a plugging problem due to a too low flow velocity, changes at the flowmeter or nozzle should be investigated first. Except for the smallest of the MixMates (M02), however, it is possible to downsize the complete Static Mixer Assembly. If you have a mixer problem that relates to polymer shear or an insufficient delivery force, a quick check can be made by removing one of the two mixer elements entirely. Since each stage of a mixer element adds incrementally to the overall PSI drop, this will tell you if the mixer is the source of the problem. If this step does help polymer activation or product delivery, then try clipping stages off the removed element one-by-one and re-installing it, until you have optimized your application.

FURROW PUMP
P.O. Box 1849 • 8525 S.W. St. Helens Drive
Wilsonville, OR 97070
(503) 682-4411 • FAX (503) 682-4421